

### 1 Installation and Startup Guide

This document covers the installation of iR-ETN40P, for the detailed specifications and operation, please refer to Datasheet, Brochure and Remote I/O User Manual. Please read all warnings, precautions, and instructions on the device carefully before use.

#### Install Environment:

Electrical Environment	The product has been tested to conform to European CE requirements. This means that the circuitry is designed to resist the effects of electrical noise. This does not guarantee noise immunity in severe cases. Proper wire routing and grounding will insure proper operation.
Environmental Considerations	<ol style="list-style-type: none"> <li>(1) Make sure that the units are installed correctly and that the operating limits are followed.</li> <li>(2) Avoid installing units in environments where severe mechanical vibration or shocks are present.</li> <li>(3) Do not operate the unit in areas subject to explosion hazards due to flammable gases, vapors or dusts, or where acid gas, such as SO<sub>2</sub> exists.</li> <li>(4) This device should be mounted in the vertical position and for use on the flat surface enclosure.</li> <li>(5) This device should be installed in an end-use fire / electrical enclosure.</li> <li>(6) This device is intended for use in a Pollution Degree 2 industrial environment and dry location, at altitudes up to 2000 m (6561 ft) without derating.</li> <li>(7) Relative Humidity: 10% ~ 90% (non-condensing)</li> </ol>
 Warning	Protection impairment if used in a manner not specified by the manufacturer. Déficit de protection si utilisé d'une manière non spécifiée par le fabricant.

### 2 Unpacking the Unit

Unpack and check the delivery. If damage is found, please contact the supplier.

**NOTE: Place the unit on a stable surface during installation. Dropping it or letting it fall may cause damage.**

The package includes:

- (1) Installation Instruction, 2-sided A4 \*1
- (2) iR-ETN40P \*1
- (3) Power Connector \*1
- (4) 14pin Terminal \*4

### 3 Installation Instructions

**Clip assembly:** Insert one side of the clip into the hole on the case. Press down firmly in the direction shown in the figure on the right until hearing the clip snap into the case.

**Clip removal:** Insert a flathead screwdriver into the gap on the clip and then lift up the screwdriver.

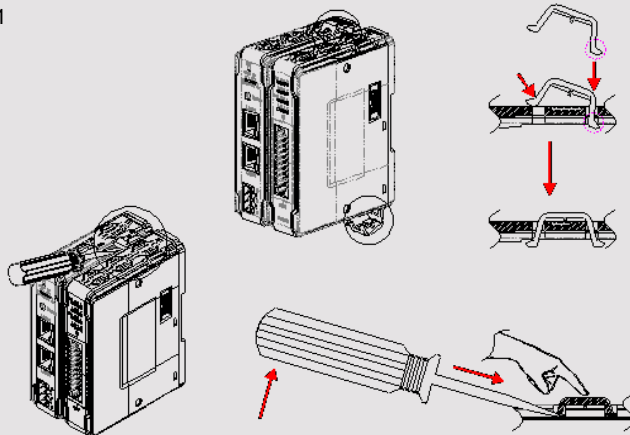

Placing a finger on the clip when lifting the screwdriver can prevent the clip from jumping away. The clip can also be removed directly by hand.

Rail mounting: DIN rail 35mm.

Panel mounting: Use two M4 or #8 panhead screws, mounting hole size is 4.6mm

Plan for adequate space around the unit and inside the enclosure, for ventilation and cables. Consider the heat from other devices inside the enclosure. The ambient temperature around the unit must be -10 ~ 60°C

**NOTE: Please do not touch any of the connectors when the unit is powered up and running.**

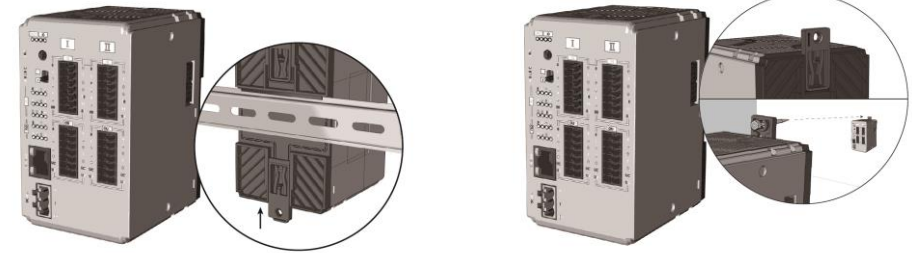

### 4 Connector and Wiring

Power Connector Specifications:

Wire AWG: 28~12

Wiring Conductor Minimum Temperature: 65°C

Wire Strip Length: 7~8 mm

**NOTE: Connect positive DC line to the '+' terminal and the DC ground to the '-' terminal.**

I/O Terminal Specifications:

Wire AWG: 24~16

Wire Strip Length: 9~10 mm

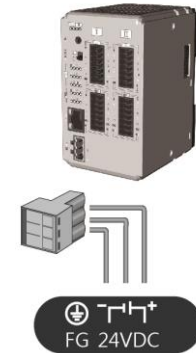

Wiring Example

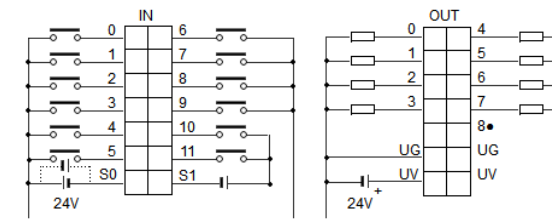

DI: 24x24VDC (Sourcing or Sinking)

DO: 24VDC (Sourcing)

0.5A per channel (Max 4A all channel)

### 5 Communication Connections

Please use a CAT.5 (or higher) Ethernet cable.



## 6 LED Indicators

### IO RUN/ERR LED

RUN LED	ERR LED	Description
OFF	OFF	Power off or no expansion module is connected
Blinking	OFF	IO initiating
Blinking	ON	IO initiation error
ON	OFF	IO working
ON	Blinking	IO module alarm
ON	ON	IO communication fault
Blinking	Blinking	Exceeding power limit or too many modules

### ENET-RUN/ERR LED

Run LED	Err LED	Description	
		Modbus TCP	EtherNet/IP
OFF	OFF	Power off or no power	
Blinking	OFF	Communicating	Pre-operational mode
ON	OFF	The device is in the OPERATIONAL state	
OFF	ON	Hardware error, communication fault	24V power error or hardware error, communication fault
ON	Blinking	Reset button is triggered	Reset button is triggered or a recoverable error has occurred

### RJ45

LINK /ACT LED	
OFF	No communication
Green Blinking	There is activity on this port
Speed LED	
OFF	Connection speed: 10Mbps
Orange ON	Connection speed: 100Mbps

## 7 Reset Button

Press and hold the reset button for more than 2 seconds after the unit starts running properly, and wait until ENET ERR LED blinks. The default parameters are shown below, the settings will take effect after cold reset.

Item	Description	Default
1	IP Address	192.168.0.212
2	Netmask	255.255.255.0

### CAUTION

**NOTE:** Make sure that all local and national electrical standards are met when installing the unit. Contact your local authorities to determine which codes apply.



Power

Use power output that meets SELV (Safety Extra-Low Voltage) requirements. The unit can be powered by DC power only, voltage range: 24VDC (-15%/+20%), compatible with most controller DC systems. The power conditioning circuitry inside the unit is accomplished by a switching power supply. The peak starting current can be as high as 2A.



Fusing Requirements

If the Power LED does not light up immediately after power up, remove power. A resettable fuse will protect against overcurrent faults in DC circuit and the resetting will take place after a period of time. Check wiring for proper connections and try to power up again.



High Voltage

A resettable fuse will prevent damage for overcurrent condition however it isn't guaranteed. DC voltage sources should provide proper isolation from main AC power and similar hazards.



Emergency Stop

A Hard-wired EMERGENCY STOP should be fitted in any system using the product.



Supply Voltage Condition

Do not power the unit and inductive DC loads, or input circuitry to the controller, with the same power supply. Note: The 24 VDC output from some controllers may not have enough current to power the unit.



Wire Routing

- Power wire length should be minimized (Max: 500m shielded, 300m unshielded).
- Please use twisted pair cables for power wire and signal wire and conform to the impedance matching.
- If wiring is to be exposed to lightning or surges, use appropriate surge suppression devices.
- Keep AC, high energy, and rapidly switching DC power wiring separated from signal wires.
- Add a resistor and capacitor in the parallel connection between the ungrounded DC power supply and the frame ground. This provides a path for static and high frequency dissipation. Typical values to use are 1M Ohm and 4700pF.
- Stranded wire or single core wire Cu 65°C (149°F).

### DANGER

The system designer should be aware that devices in Controller systems could fail and thereby create an unsafe condition. Furthermore, electrical interference in an operator interface can lead to equipment start-up, which could result in property damage and/or physical injury to the operator.



Hardware Considerations

If you use any programmable control systems that require an operator, be aware that this potential safety hazard exists and take appropriate precautions. Although the specific design steps depend on your particular application, the following precautions generally apply to installation of solid-state programmable control devices, and conform to the guidelines for installation of Controllers recommended Control Standards.



Programming Considerations

Checks should be placed in the controller to ensure that all writable registers that control critical parts of plant or machinery have limit checks built into the program, with an out-of-limit safe shut down procedure to ensure safety of personnel.

GMERT4P00\_IR-ETN40P\_Installation\_231107

## Limited Warranty

This product is limited warranted against defects in design and manufacture. The proven defective product will either be repaired or replaced, at Weintek's discretion. This warranty shall not cover any product which is

- Out of warranty period which is 12 months from the manufacturing month of the HMI products.
- Damage caused by Force Majeure, accident, negligence, improper installation or misuse.
- Product has been repaired or taken apart by unauthorized technicians.
- Products whose identification markings have been removed or damaged.