

VESA Wall Mount



◆ Features

A steel bracket used to attach the touch panel to a wall.

1. The rear enclosure of the unit is only 1cm away from the wall.
2. Pre-determine the position of the unit, and firmly fix the unit to the wall. Two pre-existing screw holes can be used to fix the unit to the bracket.

◆ Applied Models

All models with VESA mounting hole pattern 75x75mm.

◆ Installation

1. Install the mounting sleeves on the HMI unit.

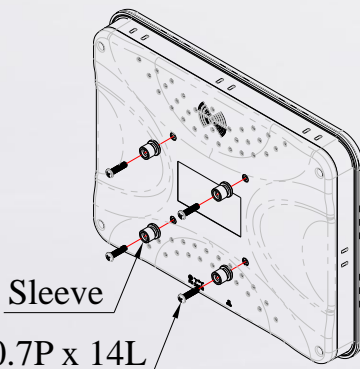

2. Install the mounting bracket on the wall.

Note: Since the wall material may differ, please prepare the suitable screws. Ø5mm

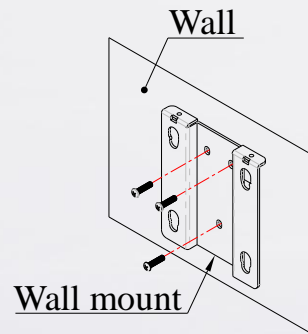

3. Install the HMI unit onto the bracket.

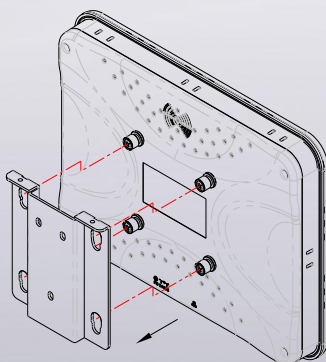

4. When necessary, insert the mounting screws in the direction as shown below to fix the unit to the bracket.

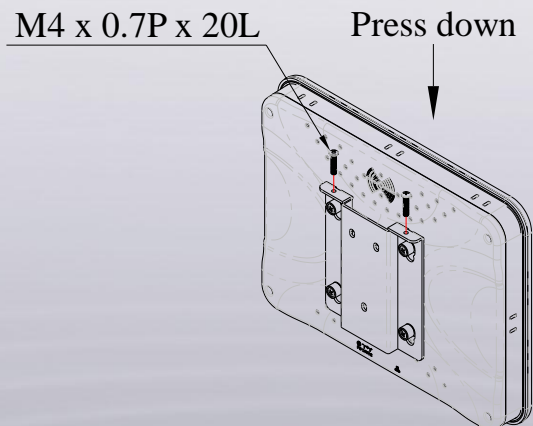

◆ Specification

RZV111010

VESA wall mount bracket V1.0 SECC (Black)
112.5x100

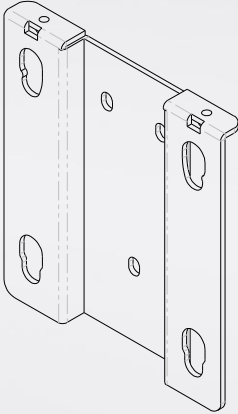

RFZ101110

Mounting sleeve V1.0 12L14 (Nickel) 10x11.2



FS1040140

Cross screw M4*14 (Nickel)



FS1040200

Cross screw M4*20 (Black)



◆ Ordering Information

□ RZVFZ1010: VESA Wall Mount Set

- RZV111010 VESA wall mount bracket, 1pcs.
- RFZ101110 Mounting sleeve, 4pcs.
- FS1040140 Cross screw M4*14 (Nickel), 4pcs.
- FS1040200 Cross screw M4*20 (Black), 2pcs.

