

MT510L

Human Machine Interface 10.4" 4 gray scale LCD display



Features

- 10.4" 640x480 4 gray scale STN LCD
- 32-bit RISC processor
- An Innovative way to debug your project
Offline Simulator, Online Simulator, Direct Online Simulator
- Built-in Recipe memory and Real Time Clock
- NEMA4/IP65 compliant front panel
- Touch screen support window operation
The MT500 allows you to create multiple windows on a screen, similar to the operation of familiar Windows programs.

Introduction

The MT500 series touch screen is the result of our continuous efforts to perfect our PLC touch screen products. Our accumulated knowledge in touch screen design has enabled us to produce these state-of-art touch screen, bringing out the PLC's full potential, and improving production line efficiency.

Specifications

- **Construction:** plastic molding housing
- **Display:** 10.4" 640x480 4 gray LCD
- **CPU and core logic:** 32-bit RISC processor
- **DRAM:** 4MB on board
- **Storage:** 2MB flash memory on board,
128KB battery backup Recipe memory
- **I/O:** 1 RS232 port (PC-HMI)
1 RS232/485 port (HMI-PLC)
- **RTC:** Built-in
- **Power input:** 24 V_{DC}, 0.5A maximum
- **Dimension (W x H x D):** 315 x 238 x 62mm
- **Weight:** Approx. 2.0kg

LCD Display

Display type	4 gray scale LCD
Display size (diagonal)	10.4"
Max colors	4
Resolution	640 x 480
Pixel pitch (HxV, mm)	0.33 x 0.33
Viewing angle (°)	40
Luminance (cd/m ²)	100
Storage temperature (°C)	-20~60
Operating temperature (°C)	0~45
Backlight	1 CCFL
Contrast ratio	18:1

Touchscreen

- **Type:** 8-wire, analog resistive
- **Resolution:** continuous
- **Light transmission:** above 80%
- **Life:** 1 million activation minimum

Environmental Specifications

- **Operating temperature:** 0° ~ 45°C (32° ~ 113°F)
- **Relative humidity:** 10% ~ 90% @ 40°C, non-condensing
- **Shock (operation):** 10 to 25Hz(X,Y,Z direction 2G 30minutes)
- **EMI:** Complies with FCC class A
- **CE:** Complies with EN50081-2 and EN50082-2 standards
- **Front panel meets NEMA4 / IP65**

Dimensions Drawing

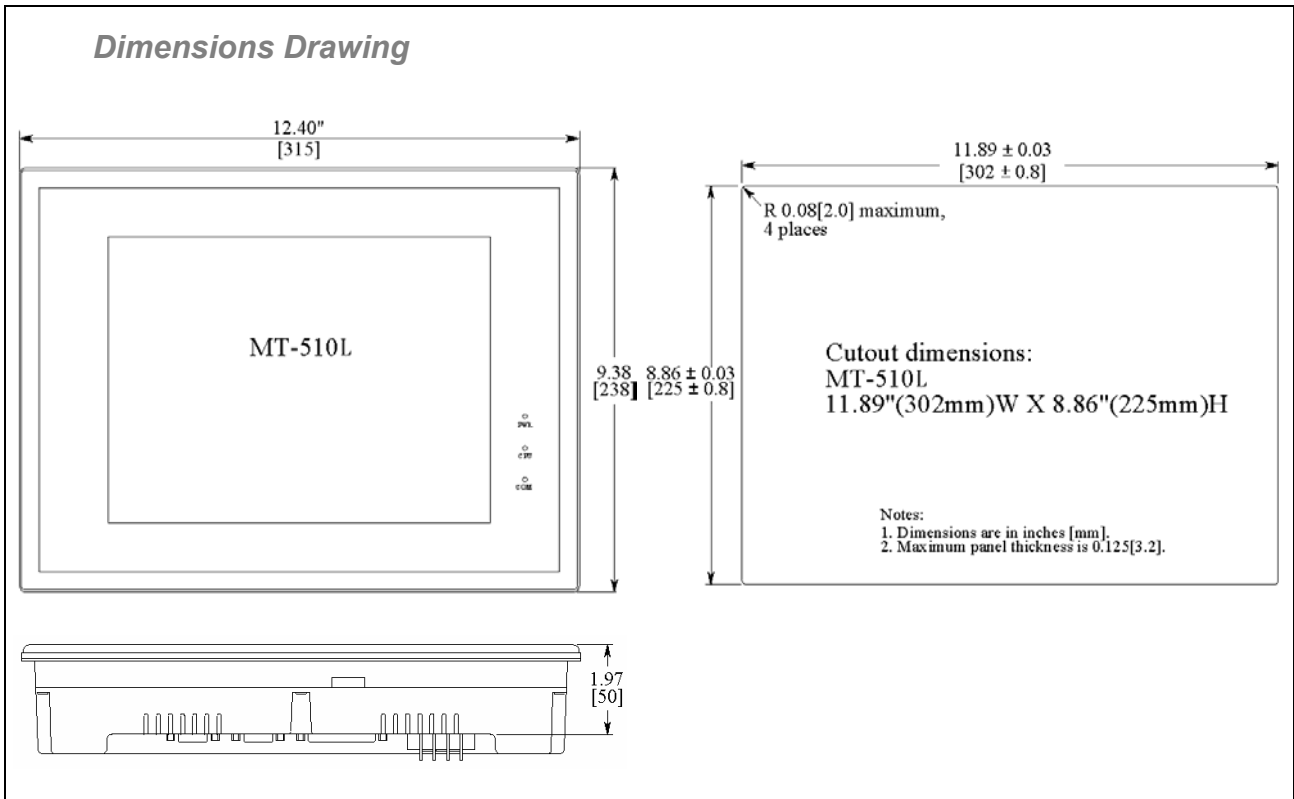

Rear View



- a. PLC [RS-232]
- b. PLC [RS-485]/PC[RS232]
- c. Printer ports
- d. Power connector
- e. DIP Switch

Ordering Information

- **MT510LV3:**
10.4" 4 gray LCD display touch panel
- **MT5_PC:**
MT500 to PC download cable