

## Installation

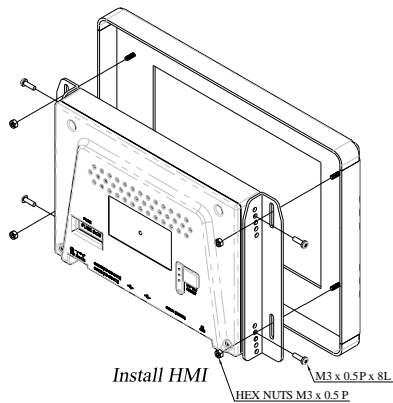

Choose the mounting holes that match your panel thickness .

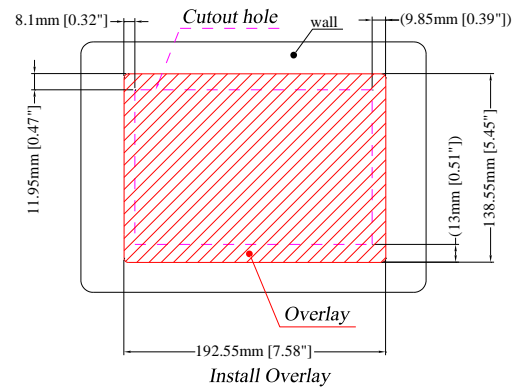
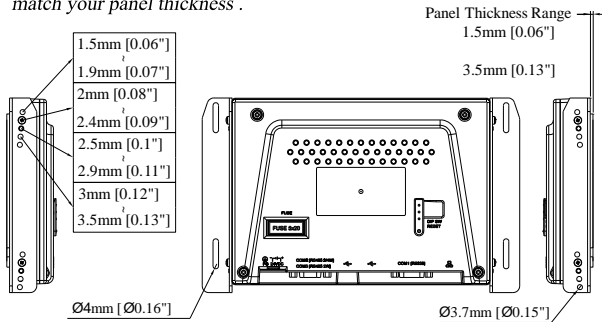

1. Around the cutout on the control cabinet, draw the reference lines for positioning the overlay.
2. Select the mounting holes according to the wall thickness of control cabinet and secure the mounting brackets onto both sides of the HMI unit.  
Wall Thickness: 1.5 mm [0.06"] ~ 3.5 mm [0.13"]
3. Secure the HMI to the cabinet by four studs.
4. Affix the overlay (user-prepared) to the cabinet front surface.