

GE Fanuc SNP-X

GE Fanuc 90 & VersaMax series PLC

<http://www.ge.com>

HMI Setting:

Parameters	Recommend	Option	Notes
PLC type	GE Fanuc SNP-X		
Com port	RS485	RS232/RS485	
Baud rate	19200	9600,19200,38400,57600,115200	Must same as the PLC setting
Parity bit	Odd	Even, Odd, None	Must same as the PLC setting
Data Bits	8	7,8	Must set as 8 to this protocol
Stop Bits	1	1, 2	Must same as the PLC setting
HMI Station No.	0	0-255	Does not apply to this protocol
PLC Station No.	0	0-255	Does not apply to this protocol

PLC Setting:

Refer to related PLC manual

Device address:

Bit/Word	Device Type	Format	Range	Memo
B	I	ddd	1-1000	Input relay
B	Q	ddd	1-1000	Output relay
B	M	ddd	1-1000	Auxiliary relay
B	G	ddd	1-7680	
B	T	ddd	1-256	
W	AI	ddd	1-1000	Analog input register
W	AQ	ddd	1-1000	Analog output register
W	R	ddd	1-32640	Data register
B	SA	ddd	1-1281	
B	SB	ddd	1-1281	
B	SC	ddd	1-1281	
B	S	ddd	1-1281	

Wiring diagram:

CPU port(90-30/VersaMax)

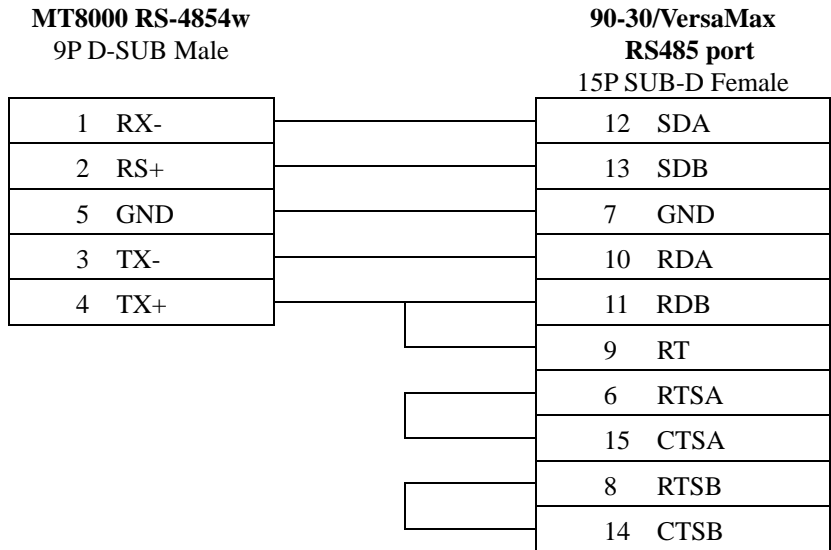

CPU port(90-30 series CPU351/352/363/364)

EasyView MT8000 HMI

9P D-SUB

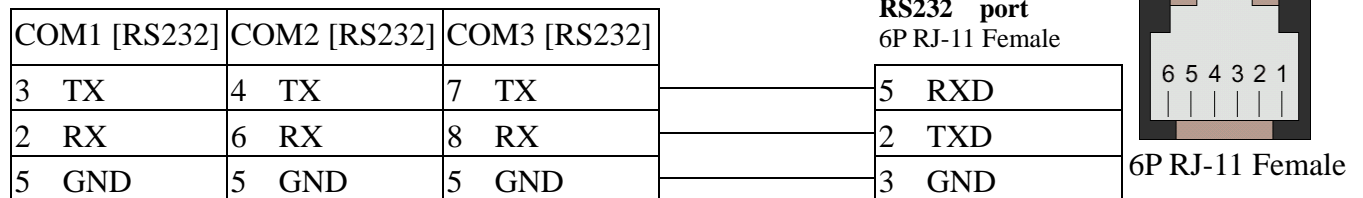

CPU port(VersaMax series CPU001/002/005/E05)

EasyView MT8000 HMI

9P D-SUB

